

Features

- Compliant with 40G Ethernet IEEE802.3ba and 40GBASE-ER4 Standard
- QSFP+ MSA compliant
- Compliant with QDR/DDR Infiniband data rates
- Up to 11.2Gb/s data rate per wavelength
- 4 CWDM lanes MUX/DEMUX design
- Up to 40km transmission on single mode fiber (SMF)
- 18.5dB link insertion loss budget
- Commercial case temperature : 0°C to 70°C
- Maximum power consumption 3.5W
- LC duplex connector
- RoHS compliant

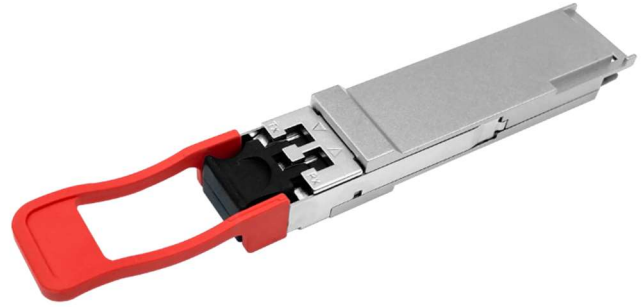

Applications

- 40GBASE-ER4 Ethernet Links
- Infiniband QDR and DDR interconnects
- Client-side 40G Telecom connections

Description

This product is a transceiver module designed for 40km optical communication applications. The design is compliant to 40GBASE-ER4 of the IEEE P802.3ba standard. The module converts 4 inputs channels (ch) of 10Gb/s electrical data to 4 CWDM optical signals, and multiplexes them into a single channel for 40Gb/s optical transmission. Reversely, on the receiver side, the module optically de-multiplexes a 40Gb/s input into 4 CWDM channels signals, and converts them to 4 channel output electrical data.

The central wavelengths of the 4 CWDM channels are 1271, 1291, 1311 and 1331nm as members of the CWDM wavelength grid defined in ITU-T G.694.2. It contains a duplex LC connector for the optical interface and a 148-pin connector for the electrical interface. To minimize the optical dispersion in the long-haul system, single-mode (SMF) has to be applied in this module.

The product is designed with form factor, optical/electrical connection and digital diagnostic interface according to the QSFP+ Multi-Source Agreement (MSA). It has been designed to meet the harshest external operating conditions including temperature, humidity and EMI interference.

Block Diagram of Transceiver

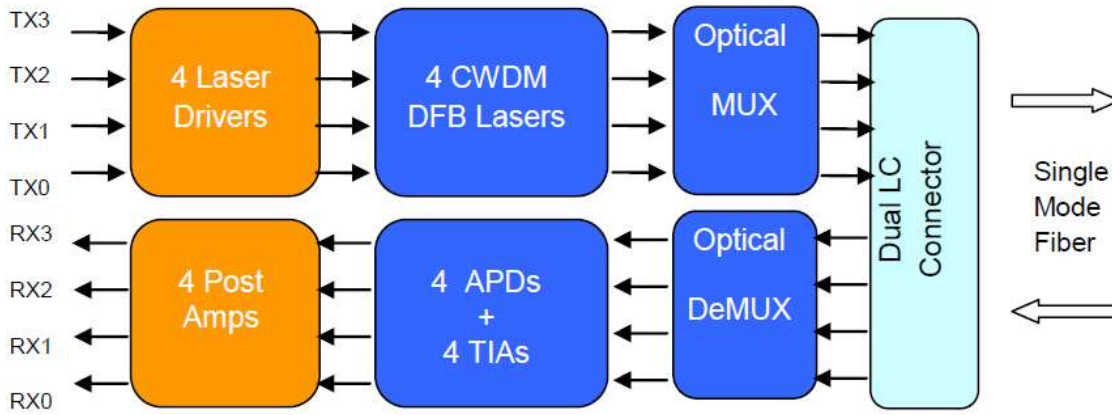

Absolute Maximum Ratings

Parameter	Symbol	Min.	Max.	Units	Note
Storage Ambient Temperature	T_{STG}	-40	85	°C	
Operating Case Temperature	T_{OP}	0	70	°C	
Power Supply Voltage	V_{CC}	-0.5	3.6	V	
Relative Humidity (non-condensation)	RH	0	85	%	
Damaged Threshold , each Lane	THd	3.8		dBm	

Recommended Operating Conditions

Parameter	Symbol	Min	Typ.	Max	Unit
Operating Case Temperature	T_{OP}	0		+70	°C
Power Supply Voltage	V_{CC}	3.135	3.3	3.465	V
Data Rate, each Lane			10.3125	11.2	Gb/s
Control Input Voltage High		2		V_{CC}	V
Control Input Voltage Low		0		0.8	V
Link Distance with G.652	D			40	km

Diagnostics Monitoring

Parameter	Symbol	Accuracy	Units	Notes
Temperature monitor absolute error	DMI_Temp	±3	°C	Over operating temperature range
Supply voltage monitor absolute error	DMI_VCC	±0.1	V	Over full operating range
Channel RX power monitor absolute error	DMI_RX_Ch	±2	dB	1
Channel Bias current monitor	DMI_Ibias_Ch	±10%	mA	
Channel TX power monitor absolute error	DMI_TX_Ch	±2	dB	1

Note:

- Due to measurement accuracy of different single mode fibers, there could be an additional +/-1 dB fluctuation, or a +/- 3 dB total accuracy.

Optical Characteristics

Parameter	Symbol	Min	Typ	Max	Unit	Notes
Wavelength Assignment	L0	1264.5	1271	1277.5	nm	
	L1	1284.5	1291	1297.5	nm	
	L2	1304.5	1311	1317.5	nm	
	L3	1324.5	1331	1337.5	nm	
Transmitter						
Side Mode Suppression Ratio	SMSR	30			dB	
Total Average Launch Power	P_T			10.5	dBm	
Average Launch Power, each lane	P_{AVG}	-2.7		4.5	dBm	
Optical Modulation Amplitude (OMA) each lane	P_{OMA}	0.3		5.0	dBm	1
Difference in Launch Power between any Two Lanes (OMA)	$P_{tx,diff}$			4.7	dB	
Launch Power in OMA minus Transmitter and Dispersion Penalty (TDP) each lane		-0.5			dBm	
TDP, each lane	TDP			2.6	dB	
Extinction Ratio	ER	5.5			dB	
Relative Intensity Noise	RIN			-128	dB/Hz	12dB reflection
Optical Return Loss Tolerance	TOL			20	dB	
Transmitter Reflectance	R_T			-12	dB	

Transmitter Eye Mask Definition (X1, X2, X3, Y1, Y2, Y3)		{0.25,0.4,0.45,0.25,0.28,0.4}		
Average Launch Power OFF Transmitter each lane	<i>P_{off}</i>		-30	dBm
Receiver				
Damage Threshold, each lane	<i>TH_d</i>	3.8		dBm 2
Average Receive Power, each lane		-21.2	-4.5	dBm
Receiver Reflectance	<i>R_R</i>		-26	dB
Receiver Power (OMA) each lane			4	dBm
Receiver Sensitivity (OMA) each lane	<i>SEN</i>		-19	dBm
Stressed Receiver Sensitivity (OMA) each lane			-16.8	dBm 3
Difference in Receiver Power between any Two Lanes (OMA)	<i>Prx,diff</i>		7	dB
LOS Assert	<i>LOSA</i>	-35		dBm
LOS Deassert	<i>LOSD</i>		-20	dBm
LOS Hysteresis	<i>LOSH</i>	0.5		dB
Receiver Electrical 3 dB upper Cutoff Frequency each lane	<i>F_c</i>		12.3	GHz

Notes:

1. Even if the TDP < 0.8 dB, the OMA min must exceed the minimum value specified here.
2. The receiver shall be able to tolerate, without damage, continuous exposure to a modulated optical input signal having this power level on one lane. The receiver does not have to operate correctly at this input power.
3. Measured with conformance test signal at receiver input for BER = 1x10⁻¹².
4. Vertical eye closure penalty and stressed eye jitter are test conditions for measuring stressed receiver sensitivity. They are not characteristics of the receiver.

Electrical Characteristics

Parameter	Symbol	Min.	Typ.	Max.	Units	Note
Power Consumption				3.5	W	
Supply Current	I _{cc}			1.1	A	
Transceiver Power-on Initialization Time				2000	ms	1
Transmitter (each lane)						
Single-ended Input Voltage Tolerance (Note 2)		-0.3		4.0	V	Referred to TP1 signal common
AC Common Mode Input Voltage Tolerance		15			mV	RMS
Differential Input Voltage Swing Threshold		50			mVpp	LOSA Threshold
Differential Input Voltage Swing	V _{in,pp}	190		700	mVpp	
Differential Input Impedance	Z _{in}	90	100	110	Ohm	
Differential Input Return Loss		See IEEE 802.3ba 86A.4.11			dB	10MHz-11.1GHz
J2 Jitter Tolerance	Jt2	0.17			UI	
J9 Jitter Tolerance	Jt9	0.29			UI	
Data Dependent Pulse Width Shrinkage (DDPWS) Tolerance		0.07			UI	
Eye Mask Coordinates {X1, X2, Y1, Y2}		{0.11, 0.31, 95, 350}			UI / mV	Hit Ratio=5x10 ⁻⁵
Receiver (each Lane)						
Single-ended Output Voltage		-0.3		4.0	V	Referred to signal common
AC Common Mode Output Voltage				7.5	mV	RMS
Differential Output Impedance	Z _{out}	90	100	110	Ohm	
Termination Mismatch at 1MHz				5	%	
Differential Output Return Loss		See IEEE 802.3ba 86A.4.2.1			dB	10MHz~11.1GHz
Common Mode Output Return Loss		See IEEE 802.3ba 86A.4.2.2			dB	10MHz~11.1GHz
Output Transition Time		28			ps	20% to 80%
J2 Jitter Output	Jo2			0.42	UI	
J9 Jitter Output	Jo9			0.65	UI	
Eye Mask Coordinates {X1, X2}		{0.29, 0.5, 150, 425}			UI mV	Hit Ration=5x10 ⁻⁵

Y1, Y2}

Notes:

1. Power-on Initialization Time is the time from when the power supply voltages reach and remain above the minimum recommended operating supply voltages to the time when the module is fully functional.
2. The single ended input voltage tolerance is the allowable range of the instantaneous input signals

Dimensions

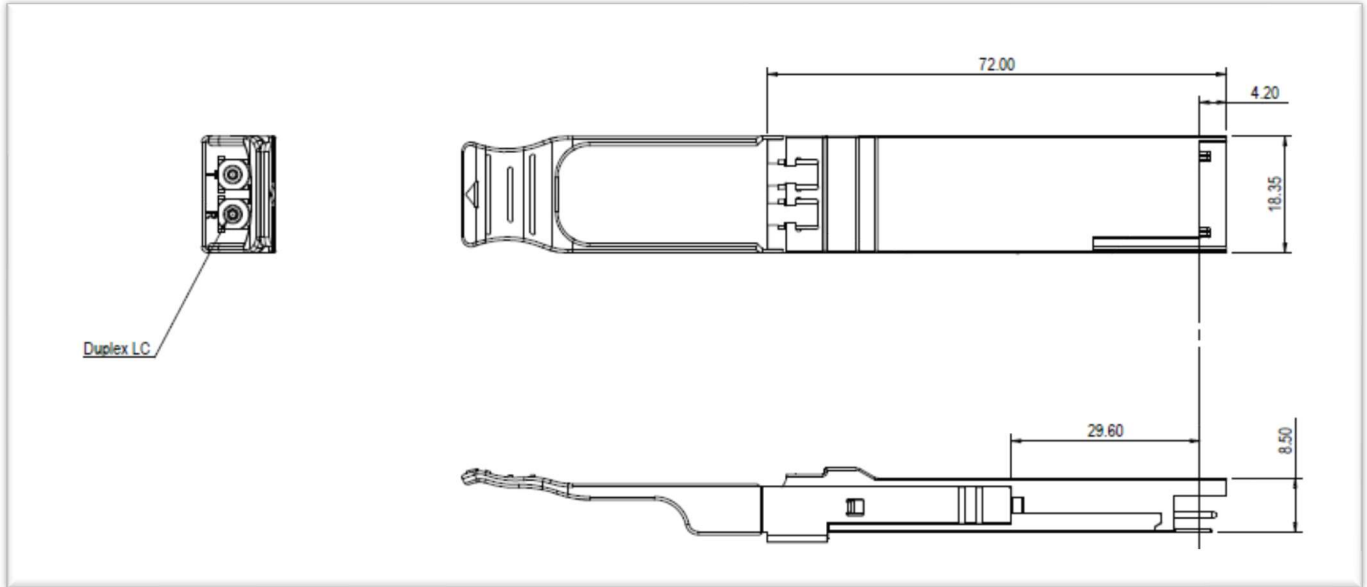

Pin Assignment

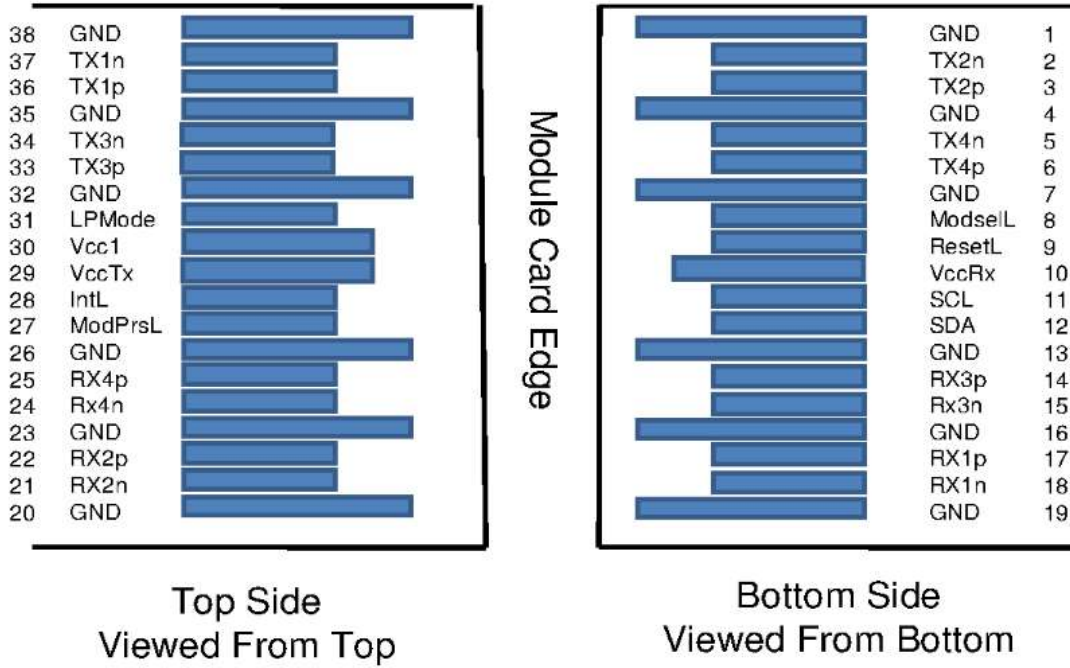

Pin Descriptions

PIN	Logic	Symbol	Description	Note
1		GND	Ground	1
2	CML-I	Tx2n	Transmitter Inverted Data Input	
3	CML-I	Tx2p	Transmitter Non-Inverted Data output	
4		GND	Ground	1
5	CML-I	Tx4n	Transmitter inverted Data Input	
6	CML-I	Tx4p	Transmitter Non-Inverted Data output	
7		GND	Ground	1
8	LVTLL-I	ModSelL	Module Select	
9	LVTLL-I	ResetL	Module Reset	
10		VccRx	+3.3V Power Supply Receiver	2
11	LVC MOS-I/O	SCL	2-Wire Serial Interface Clock	
12	LVC MOS-I/O	SDA	2-Wire Serial Interface Data	
13		GNC	Ground	
14	CML-O	Rx3p	Receiver Non-Inverted Data output	
15	CML-O	Rx3n	Receiver Inverted Data output	
16		GND	Ground	1
17	CML-O	Rx1p	Receiver Non-Inverted Data Output	
18	CML-O	Rx1n	Receiver Inverted Data Output	
19		GND	Ground	1
20		GND	Ground	1
21	CML-O	Rx2n	Receiver Inverted Data output	
22	CML-O	Rx2p	Receiver Non-Inverted Data output	
23		GND	Ground	1
24	CML-O	Rx4n	Receiver Inverted Data output	1
25	CML-O	Rx4p	Receiver Non-Inverted Data output	
26		GND	Ground	1
27	LVTTL-O	ModPrsL	Module Present	
28	LVTTL-O	IntL	Interrupt	
29		VccTx	+3.3V Power Supply transmitter	2
30		Vcc1	+3.3V Power Supply	2
31	LVTTL-I	LPMODE	Low Power Mode	
32		GND	Ground	1
33	CML-I	Tx3p	Transmitter Non-Inverted Data Input	

34	CML-I	Tx3n	Transmitter Inverted Data Output	
35		GND	Ground	1
36	CML-I	Tx1p	Transmitter Non-Inverted Data Input	
37	CML-I	Tx1n	Transmitter Inverted Data Output	
38		GND	Ground	1

Notes:

1. GND is the symbol for signal and supply (power) common for the QSFP+ module. All are common within the QSFP+ module and all module voltages are referenced to this potential unless otherwise noted. Connect these directly to the host board signal-common ground plane.
2. VccRx, Vcc1 and VccTx are the receiver and transmitter power supplies and shall be applied concurrently. Recommended host board power supply filtering is shown below. Vcc Rx, Vcc1 and Vcc Tx may be internally connected within the QSFP+ transceiver module in any combination. The connector pins are each rated for a maximum current of 500mA.

Optical Receptacle Cleaning Recommendations

All fiber stubs inside the receptacle portions were cleaned before shipment. In the event of contamination of the optical ports, the recommended cleaning process is the use of forced nitrogen. If contamination is thought to have remained, the optical ports can be cleaned using a NTT international Cletop® stick type and HFE7100 cleaning fluid. Before the mating of patch-cord, the fiber end should be cleaned up by using Cletop® cleaning cassette.

Cleaning of patch-cord

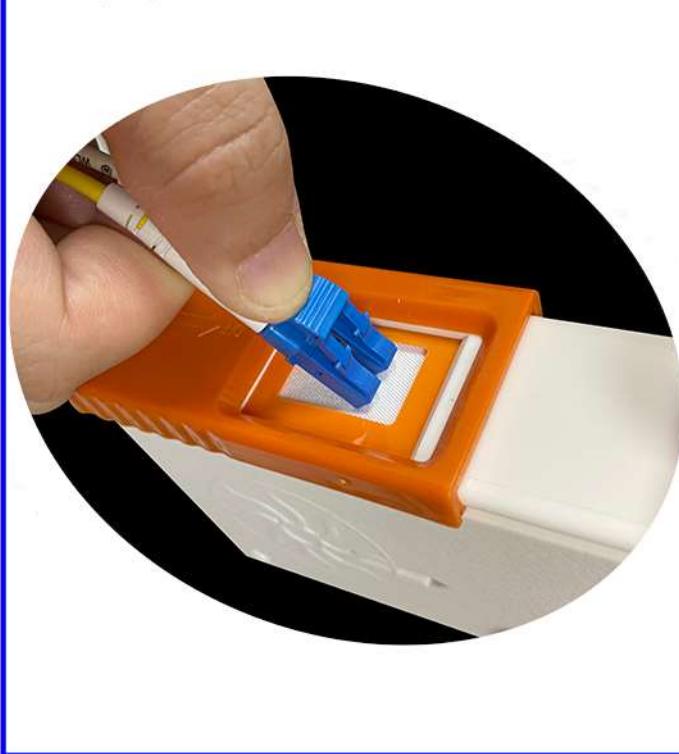

Cleaning of fiber stub

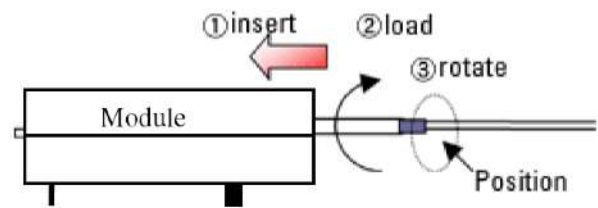

1. Insert
Ensure that stick is held straight when inserting into sleeve.
2. Load
Apply sufficient pressure (approx 600-700g) to ensure ferrule a little depressed in sleeve.
3. Rotate
Rotate stick clockwise 4-5 times, while ensuring direct contact with ferrule end-face is maintained.

*Notice: Number of possible wipes:
Maintenance (repair) ~1 use / piece
Equipment construction: 4 uses / piece (max.)*

Note: The pictures were extracted from NTT-ME website. And the Cletop® is a trademark registered by NTT-ME

Ordering Information

<i>Model Number</i>	<i>Part Number</i>	<i>Voltage</i>	<i>Temperature</i>
40G QSFP ER4	OPCS-S40-13-CB	3.3V	0°C to 70 °C

Modification History

<i>Revision</i>	<i>Date</i>	<i>Description</i>
A1	Aug. 2013	Initial Release

Note: All information contained in this document is subject to change without notice.