

Features

- QSFP28 MSA compliant
- Support 100GE aggregate bit rates
- Support KP4 FEC @100G data rate
- Two independent full-duplex channels
- Up to 100m OM4 MMF transmission
- Operating case temperature: 0 to 70°C
- Single 3.3V power supply
- Maximum power consumption 4W
- LC optical connector
- RoHS-6 compliant

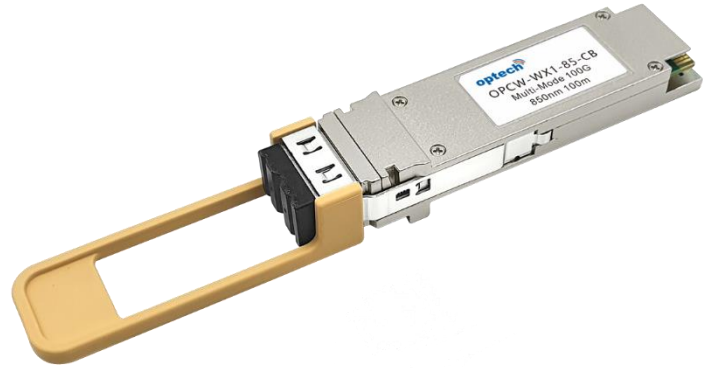

Applications

- Data Center Interconnect
- 100G Ethernet
- Infiniband HDR

Description

This product can support 100Gb/s bit rates. It is a parallel Quad Small Form-factor Pluggable (QSFP28) Bi-Direction optical module. The module integrates four host electrical data into two optical lanes (by Dual Wavelength VCSEL Bi-Directional Optical Interface, 850nm and 900nm) to allow optical communication over a 2-fiber duplex LC optical multi-mode fiber. Reversely, on the receiver side, the module de-multiplexes 2 sets of optical input signal and converts them to 4 channels of electrical data.

Absolute Maximum Ratings

Parameter	Symbol	Min.	Max.	Units	Note
Storage Temperature	T_s	-40	85	°C	
Operating Case Temperature	T_{op}	10	70	°C	
Power Supply Voltage	V_{cc}	-0.5	3.6	V	
Relative Humidity (non-condensation)	RH	0	85	%	
Damage Threshold, each Lane	TH_d	5		dBm	

Recommended Operating Conditions

Parameter	Symbol	Min.	Typ.	Max.	Units	Note
Operating Case Temperature	T_{op}	10		70	°C	
Power Supply Voltage	V_{cc}	3.135	3.3	3.465	V	
Data Rate Accuracy		-100		100	ppm	
Pre-FEC Bit Error Ratio				2.4×10^{-4}		
Post-FEC Bit Error Ratio				1×10^{-12}		1
Control Input Voltage High		2		V_{cc}	V	
Control Input Voltage Low		0		0.8	V	
Link Distance	OM3			70	m	2
	OM4			100	m	2
	OM5			150	m	2

Notes:

1. FEC provided by host system.
2. FEC required on host system to support maximum distance.

Diagnostics Monitoring

Parameter	Symbol	Accuracy	Unit	Notes
Temperature monitor absolute error	DMI_Temp	± 3	°C	Over operating temperature range
Supply voltage monitor absolute error	DMI_VCC	± 0.15	V	Over full operating range
Channel RX power monitor absolute error	DMI_RX_Ch	± 2	dB	1
Channel Bias current monitor	DMI_Ibias_Ch	± 10%	mA	
Channel TX power monitor absolute error	DMI_TX_Ch	± 2	dB	1

Notes:

1. Due to measurement accuracy of different single mode fibers, there could be an additional +/- 1 dB fluctuation, or a +/- 3 dB total accuracy.

Transceiver Block Diagram

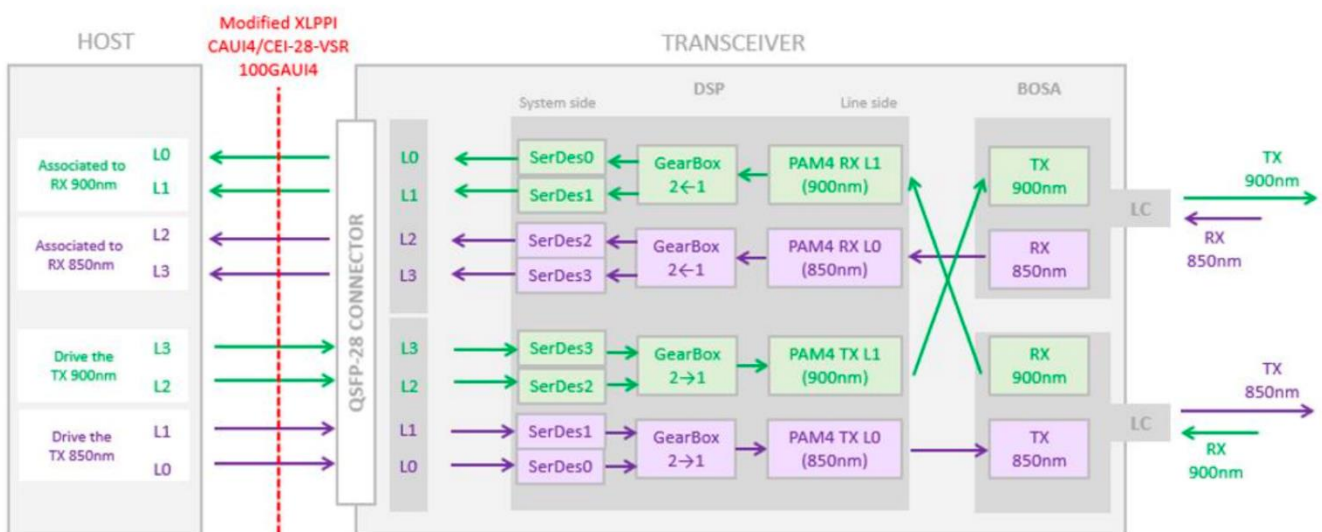

Optical Characteristics

Parameter	Symbol	Min.	Typ.	Max.	Units	Note
Center Wavelength Line0	λ_c	844	850	863	nm	
Center Wavelength Line1	λ_c	900	910	918	nm	
Transmitter						
RMS Spectral Width	$\Delta\lambda_{rms}$			$\lambda_1: 0.6$ $\lambda_2: 0.65$	nm	
Average Launch Power, each lane	P_{AVG}	-6.2		4	dBm	
Optical Modulation Amplitude (OMA _{outer}), each lane	P_{OMA}	-4.2		3	dBm	1
Peak Power, each Lane				--	dBm	
Launch power in OMA minus TDP, each lane		-5.6			dBm	
TDECQ, each lane				4.5	dB	
Extinction Ratio	ER	3.0			dB	
Transmitter transition time, each lane				31	ps	
RIN 12 OMA				-128	dB/Hz	
Optical Return Loss Tolerance	TOL			12	dB	
Average Launch Power of OFF Transmitter, each Lane	P_{off}			-30	dBm	
Encircled Flux			$\geq 86\%$ at 19 μm $\geq 30\%$ at 4.5 μm			2
Signaling rate, each lane			26.5625 \pm 100ppm		Gbps	
Receiver						
Damage Threshold, each Lane	TH_d	5			dBm	3
Average Receiver Power, each Lane		-8.2			dBm	4
Average power at receiver input, each lane (overload)				4	dBm	
Receiver Reflectance	R_R			-12	dB	
Stressed receiver sensitivity in OMA Lane2				-3.5	dBm	5
Receiver sensitivity (OMA outer), each lane				Max (-6.6, SECQ-8) as per IEEEcl150	dBm	
LOS Assert	$LOSA$	-30		-14.2	dBm	

LOS Deassert	<i>LOSD</i>	-11.2	dBm
LOS Hysteresis	<i>LOSH</i>	0.5	dB

Note:

1. Even if the mTDEC<0.9dB, the OMA (min) must exceed this value.
2. If measured into type A1a.2 50um fiber in accordance with IEC 61280-1-4.
3. The receiver shall be able to tolerate, without damage, continuous exposure to a modulated optical input signal having this power level on one lane. The receiver does not have to operate correctly at this input power.
4. Average receive power, each lane (min) is informative and not the principal indicator of signal strength. A received power below this value cannot be compliant; however, a value above this does not ensure compliance.
5. Measured with conformance test signal at TP3 as per following:

Stressed eye closure (SECq), each lane	4.5	dB
OMA of each aggressor, each lane	3	dBm

Electrical Characteristics

Parameter	Symbol	Min.	Typ.	Max.	Units	Note
Power Consumption				4	W	
Supply Current	<i>I_{cc}</i>			1.21	A	
Transmitter (each lane)						
Overload Differential Voltage pk-pk	<i>TP1a</i>	900			mV	
Common Mode Voltage (V _{cm})	<i>TP1</i>	-350		2850	mV	1
Differential Termination Resistance Mismatch	<i>TP1</i>			10	%	at 1MHz
Differential Return Loss (SDD11)	<i>TP1</i>			See CEI-28G-VSR Equation 13-19	dB	
Common Mode to Differential conversion and Differential to Common Mode conversion (SDC11, SCD11)	<i>TP1</i>			See CEI-28G-VSR Equation 13-20	dB	2
Stressed Input Test	<i>TP1a</i>		See CEI-28G-VSR Section 13.3.11.2.1			V
Receiver (each lane)						
Differential Voltage, pk-pk	<i>TP4</i>			900	mV	
Common Mode Voltage (V _{cm})	<i>TP4</i>	-350		2850	mV	1
Common Mode Noise, RMS	<i>TP4</i>			17.5	mV	
Differential Termination Resistance Mismatch	<i>TP4</i>			10	%	at 1 MHz
Differential Return Loss (SDD22)	<i>TP4</i>			See CEI-28G-VSR Equation 13-19	dB	
Common to Mode to Differential Conversion and Differential to Common Mode conversion (SDC22, SCD22)	<i>TP4</i>			See CEI-28G-VSR Equation 13-21	dB	

Common Mode Return Loss (SCC22)	TP4		-2	dB	2
Transition Time 20% to 80%	TP4	9.5		ps	
Vertical Eye Closure (VEC)	TP4		5.5	dB	
Eye Width at 10 ⁻¹⁵ probability (EW15)	TP4	0.57		UI	
Eye Height at 10 ⁻¹⁵ probability (EH15)	TP4	228		mV	

Notes:

1. Vcm is generated by the host. Specification includes effects of ground offset voltage.
2. From 250MHz to 30GHz

Optical Interface Lanes and Assignment

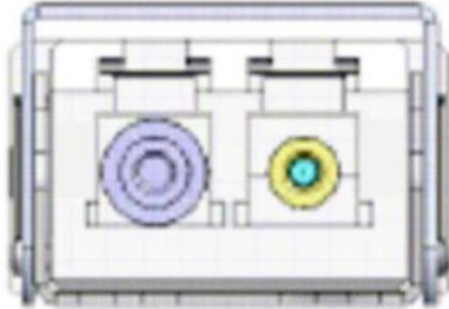

Figure 3: Outside View of the QSFP28 Module LC Receptacle

Recommended Power Supply Filter

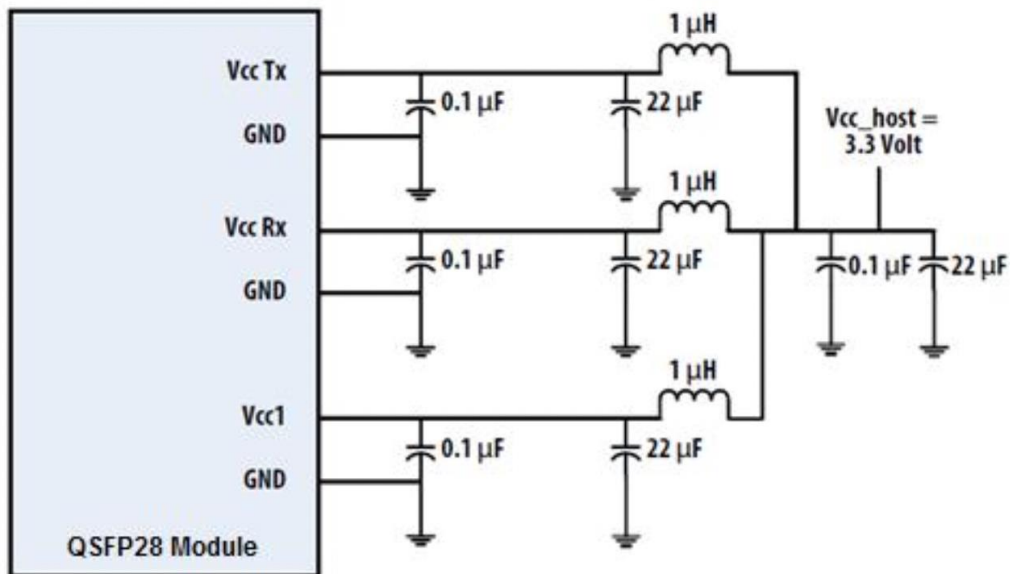

Figure 4. Recommended Power Supply Filter

Pin Descriptions

Pin	Logic	Symbol	Name/Description	Notes
1		GND	Ground	1
2	CML-I	Tx2n	Transmitter Inverted Data Input	
3	CML-I	Tx2p	Transmitter Non-Inverted Data Input	
4		GND	Ground	1
5	CML-I	Tx4n	Transmitter Inverted Data Input	
6	CML-I	Tx4p	Transmitter Non-Inverted Data Input	
7		GND	Ground	1
8	LVTTL-I	ModSelL	Module Select	
9	LVTTL-I	ResetL	Module Reset	
10		VccRx	+3.3V Power Supply Receiver	2
11	LVCMOS-I/O	SCL	2-wire serial interface clock	
12	LVCMOS-I/O	SDA	2-wire serial interface data	
13		GND	Ground	1
14	CML-O	Rx3p	Receiver Non-Inverted Data Output	
15	CML-O	Rx3n	Receiver Inverted Data Output	
16		GND	Ground	1B
17	CML-O	Rx1p	Receiver Non-Inverted Data Output	
18	CML-O	Rx1n	Receiver Inverted Data Output	
19		GND	Ground	1
20		GND	Ground	1
21	CML-O	Rx2n	Receiver Inverted Data Output	
22	CML-O	Rx2p	Receiver Non-Inverted Data Output	
23		GND	Ground	1
24	CML-O	Rx4n	Receiver Inverted Data Output	
25	CML-O	Rx4p	Receiver Non-Inverted Data Output	
26		GND	Ground	1
27	LVTTL-O	ModPrsL	Module Present	
28	LVTTL-O	IntL	Interrupt	

29		VccTx	+3.3V Power supply transmitter	2
30		Vcc1	+3.3V Power supply	2
31	LVTTL-I	LPMode	Low Power Mode	
32		GND	Ground	1
33	CML-I	Tx3p	Transmitter Non-Inverted Data Input	
34	CML-I	Tx3n	Transmitter Inverted Data Input	
35		GND	Ground	1
36	CML-I	Tx1p	Transmitter Non-Inverted Data Input	
37	CML-I	Tx1n	Transmitter Inverted Data Input	
38		GND	Ground	1

Notes:

1. GND is the symbol for signal and supply (power) common for QSFP28 modules. All are common within the QSFP28 module and all module voltages are referenced to this potential unless otherwise noted. Connect these directly to the host board signal common ground plane.
2. VccRx, Vcc1 and VccTx are the receiver and transmitter power suppliers and shall be applied concurrently. Recommended host board power supply filtering is shown in Figure 4 below. Vcc Rx, Vcc1 and Vcc Tx may be internally connected within the QSFP28 transceiver module in any combination. The connector pins are each rated for a maximum current of 1000mA

Dimensions

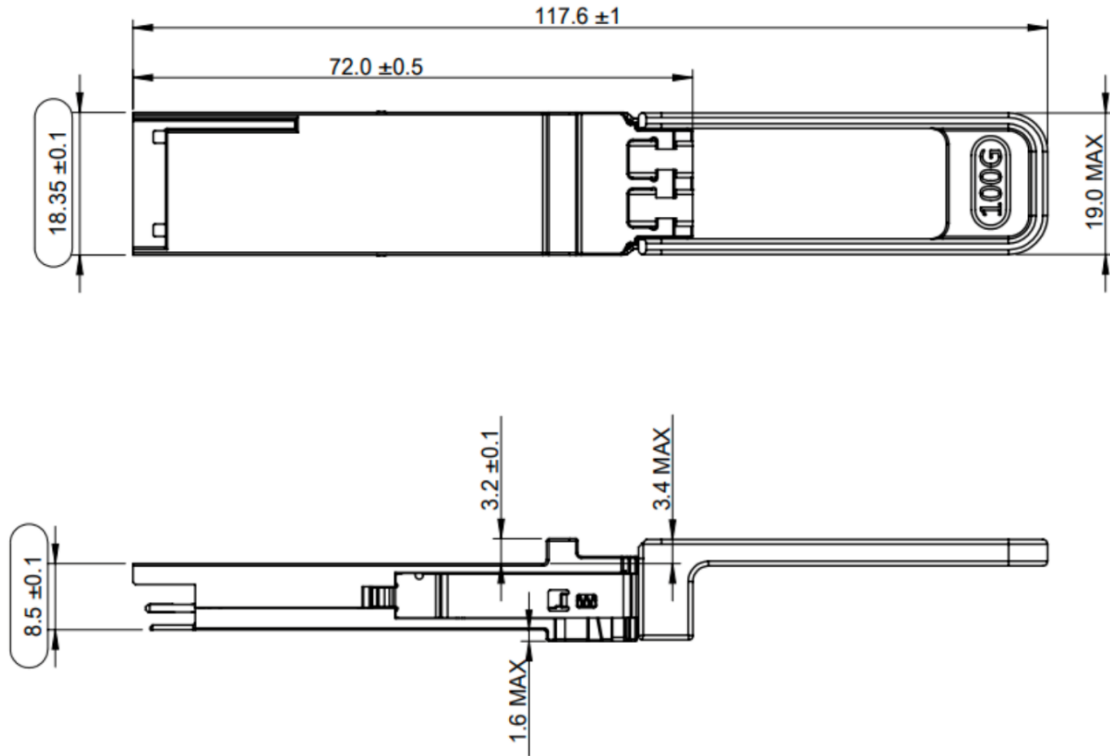

Optical Receptacle Cleaning Recommendations :

All fiber stubs inside the receptacle portions were cleaned before shipment. In the event of contamination of the optical ports, the recommended cleaning process is the use of forced nitrogen. If contamination is thought to have remained, the optical ports can be cleaned using a NTT international Cletop® stick type and HFE7100 cleaning fluid. Before the mating of patch-cord, the fiber end should be cleaned up by using Cletop® cleaning cassette.

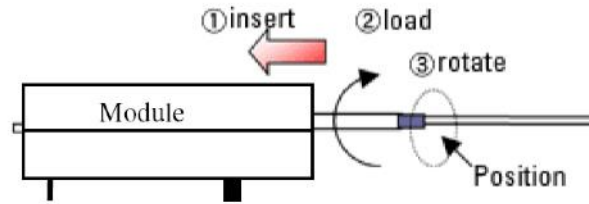
Cleaning of patch-cord	Cleaning of fiber stub
	 <ol style="list-style-type: none"> 1. Insert Ensure that stick is held straight when inserting into sleeve. 2. Load Apply sufficient pressure (approx 600-700g) to ensure ferrule a little depressed in sleeve. 3. Rotate Rotate stick clockwise 4-5 times, while ensuring direct contact with ferrule end-face is maintained. <p><i>Notice: Number of possible wipes: Maintenance (repair) ~1 use / piece Equipment construction: 4 uses / piece (max.)</i></p>

Note: The pictures were extracted from NTT-ME website. And the Cletop® is a trademark registered by NTT-ME

Ordering Information

<i>Model Number</i>	<i>Part Number</i>	<i>Voltage</i>	<i>Temperature</i>
QSFP28-100G-SR-BiDi	OPCW-WX1-85-CB	3.3V	10°C to 70 °C

Modification History

<i>Revision</i>	<i>Date</i>	<i>Description</i>
A2	FEB. 2022	Initial Release

Note: All information contained in this document is subject to change without notice.